

MODEL U002 & U003

Installation and Operating Manual

ULTRASONIC
LEVEL
SWITCH

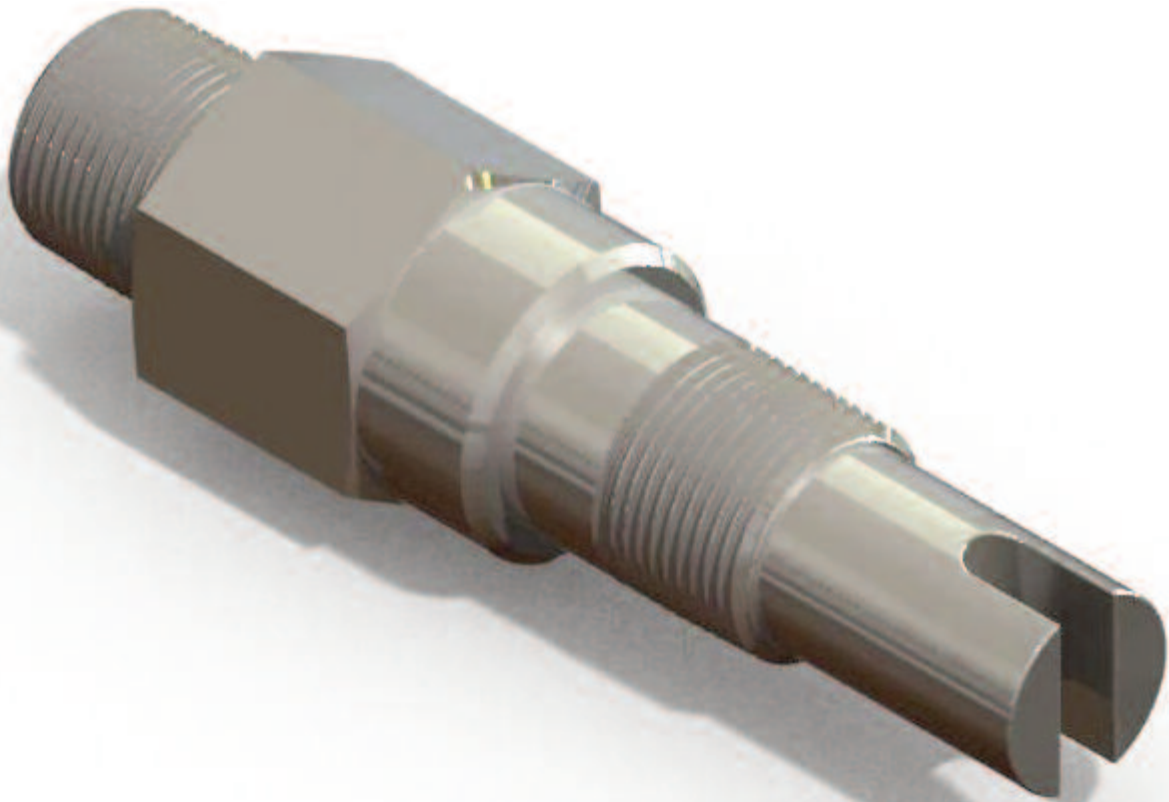

Innovative Solutions

60 Great Hill Road Naugatuck, CT 06770
ph: 203-729-6434 fax: 203-729-6696

www.innovativesensing.com

Read this Manual Before Installing

This manual provides information on the Ultrasonic Liquid Level Switch. It is important that all instructions are read carefully and followed in sequence. Detailed instructions are included in the Installation section of this manual.

Conventions Used in this Manual

Certain conventions are used in this manual to convey specific types of information. General technical material, support data, and safety information are presented in narrative form. The following styles are used for notes, cautions, and warnings.

Notes

Notes contain information that augments or clarifies an operating step. Notes do not normally contain actions. They follow the procedural steps to which they refer.

Cautions

Cautions alert the technician to special conditions that could injure personnel, damage equipment, or reduce a component's mechanical integrity. Cautions are also used to alert the technician to unsafe practices or the need for special protective equipment or specific materials. In this manual, a caution box indicates a potentially hazardous situation which, if not avoided, may result in minor or moderate injury.

Warnings

Warnings identify potentially dangerous situations or serious hazards. In this manual, a warning indicates an imminently hazardous situation which, if not avoided, could result in serious injury or death.

Safety Messages

The Ultrasonic models are designed for use in Category II, Pollution Degree 2 installations. Follow all standard industry procedures for servicing electrical and computer equipment when working with or around high voltage. Always shut off the power supply before touching any components.

Electrical components are sensitive to electrostatic discharge. To prevent equipment damage, observe safety procedures when working with electrostatic sensitive components.

This device complies with Part 15 of the FCC rules. Operation is subject to the following two conditions: (1) This device may not cause harmful interference, and (2) This device must accept any interference received, including interference that may cause undesired operation.

WARNING! Explosion hazard. Do not connect or disconnect equipment unless power has been switched off or the area is known to be non-hazardous.

Low Voltage Directive

For use in Category II installations. If equipment is used in a manner not specified by manufacturer, protection provided by equipment may be impaired.

Notice of Trademark, Copyright, and Limitations

Copyright © 2008 Solutions With Innovation LLC; D.B.A. Innovative Solutions
All rights reserved.

Innovative Solutions reserves the right to make changes to the product described in this manual at any time without notice. Innovative Solutions makes no warranty with respect to the accuracy of the information in this manual.

Warranty

All Innovative Solutions electronic level and flow products are warranted free of defects in materials or workmanship for one full year from the date of original factory shipment.

If returned within the warranty period; and, upon factory inspection of the control, the cause of the claim is determined to be covered under the warranty; then, Innovative Solutions will repair or replace the control at no cost to the purchaser (or owner) other than transportation.

Innovative Solutions shall not be liable for misapplication, labor claims, direct or consequential damage or expense arising from the installation or use of equipment.

There are no other warranties expressed or implied, except special written warranties covering some Innovative Solutions products.

Quality Assurance

The quality assurance system in place at Innovative Solutions guarantees the highest level of quality throughout the company. We are committed to providing full customer satisfaction both in quality products and quality service.

MODEL U002 & U003

ULTRASONIC LEVEL SWITCH

Table of Contents

1.0 Introduction

1.1 Description	1
1.2 Principle of Operation	1
1.3 Getting Started	1

2.0 Installation

2.1 Unpacking	2
2.2 Electrostatic Discharge (ESD) Handling Procedure ..	2
2.3 Mounting.....	2
2.4 Wiring	3
2.4.1 Relay Output.....	3
2.4.2 Current Shift Output.....	3

3.0 Reference Information

3.1 Specifications	4
3.1.1 Physical.....	4
3.1.2 Electrical	4
3.1.3 Environmental	4
3.2 Replacement Parts	4
3.3 Troubleshooting.....	5
3.4 Model Numbers	5

1.0 Introduction

1.1 Description

Model U002 & U003 Ultrasonic Level Switches are compact integral units that utilize pulsed signal technology to perform high or low level measurement in a wide variety of liquid applications. These switches feature pulsed electronics that are encapsulated at the top of the process fitting and a 316 stainless steel tip-sensitive transducer. Model U003 features a 1 amp SPDT relay output and is also available with a current shift output.

1.2 Principle of Operation

The U002 & U003 level switches utilize ultrasonic energy to detect the presence or absence of liquid in a tip sensitive transducer gap. The principle of contact ultrasonic technology is that high frequency sound waves are easily transmitted across a transducer gap in the presence of liquid, but are attenuated when the gap is dry (see Figure 1).

The Model U002 & U003 uses this ultrasonic technology to perform liquid level measurement in a wide variety of process media and application conditions.

A pair of piezoelectric crystals are encapsulated in epoxy at the tip of the transducer. The crystals are made of a ceramic material that vibrates at a given frequency when subjected to an applied voltage. The transmit crystal converts the applied voltage from the electronics into an ultrasonic signal. When liquid is present in the gap, the receive crystal is able to sense the ultrasonic signal from the transmit crystal and convert it back to an electrical signal. This signal is sent to the electronics to indicate the presence of liquid in the transducer gap. When there is no liquid present, the ultrasonic signal is attenuated and is not detected by the receive crystal.

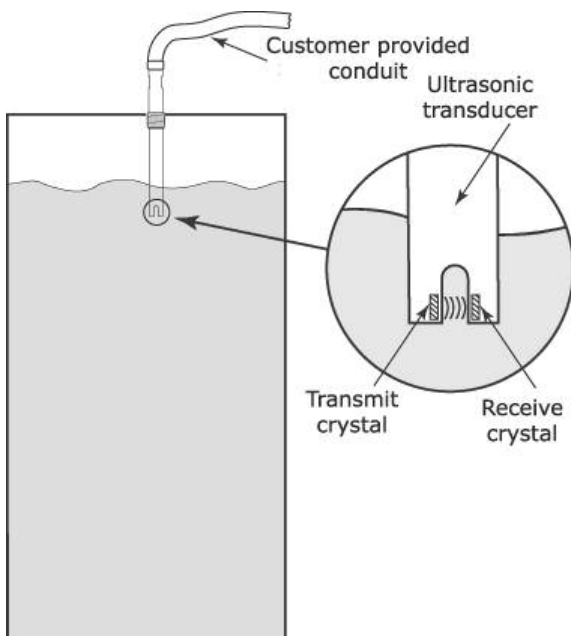

Figure 1
Ultrasonic signal transmission
across transducer gap

1.3 Getting Started

Model U002 & U003 is extremely compact level switches with electronics completely potted in an extension piece directly above the stainless steel transducer. The 12" (305 mm) long 18 AWG flying lead wires are typically terminated either inside conduit or a customer supplied junction box. No special tools are required to perform installation.

2.0 Installation

2.1 Unpacking

Unpack the instrument carefully. Inspect all units for damage. Report any concealed damage to carrier within 24 hours. Check the contents of the packing slip and purchase order. Check and record the serial number for future reference when ordering parts.

serial number

2.2 Electrostatic Discharge (ESD) Handling Procedure

All Innovative Solutions electronic instruments are manufactured to the highest quality standards. These instruments use electronic components that may be damaged by static electricity present in most work environments.

Make sure that all electrical connections are completely made and none are partial or floating. Ground all equipment to a good, earth ground.

2.3 Mounting

Model U002 & U003 level switches may be mounted in a variety of positions as shown in Figures 2 through 5.

Proper orientation of the transducer gap will facilitate maximum performance in difficult applications. When the switch is mounted horizontally, the transducer gap must be turned vertical to allow proper drainage of liquid out of the gap. The wrench flats on the mounting nut are aligned with the transducer gap; therefore, proper transducer mounting can be achieved by aligning the mounting nut flats in a vertical orientation. See Figure 4.

When installed in a nozzle or pipe, the transducer gap must extend into the tank at least one inch beyond the inside tank wall. Refer to Figure 5.

Screw transducer into the opening using a wrench on the transducer mounting nut flats. If flanged, bolt unit to mating flange with proper gasket. Use thread tape or suitable pipe compound on the threads. Do not over-tighten.

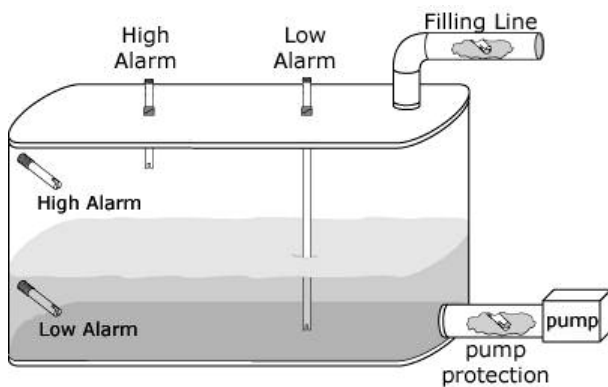
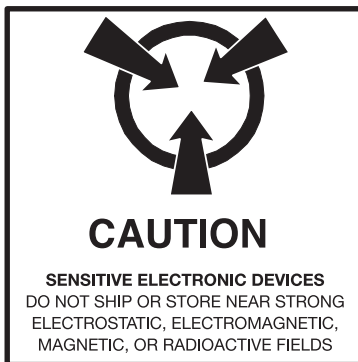

Figure 2
Typical Mounting Orientations

2.4 Wiring

2.4.1 Model U003 (Relay Output)

Wiring terminations for the Model U003 are shown in Figure 3. The six wires coming out of the switch are 18 AWG. These wires should be connected to field wiring that is 14 to 22 AWG.

Caution: Conduit should be installed onto the $\frac{3}{4}$ " NPT connection on the back of the unit. An approved seal drain fitting should be used to prevent moisture from entering the switch. All wiring, conduit, and electrical fittings must conform to local electrical codes for the location selected.

Field wiring should be connected as follows:

1. Connect power wiring via the red (+) and black (-) wires.
2. Green wire should be connected to earth ground.
3. The SPDT relay is connected:
 - Orange wire is NO
 - Blue wire is NC
 - Yellow wire is COM

2.4.2 Model U002 (Current Shift Output)

Wiring terminations for the Model U002 are shown in Figure 4. The three wires coming out of the switch are 18 AWG. These wires should be connected to field wiring that is 14 to 22 AWG.

Caution: Conduit should be installed onto the $\frac{3}{4}$ " NPT connection on the back of the unit. An approved seal drain fitting should be used to prevent moisture from entering the switch. All wiring, conduit, and electrical fittings must conform to local electrical codes for the location selected.

Field wiring should be connected as follows:

1. Connect power wiring via the red (+) and black (-) wires.
2. Green wire should be connected to earth ground.

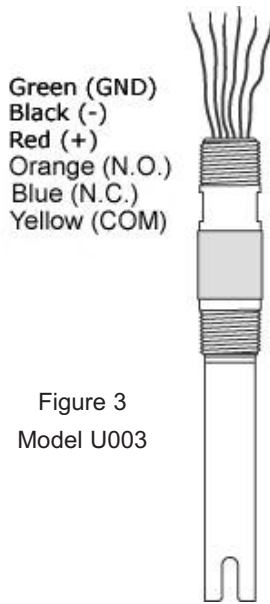

Figure 3
Model U003

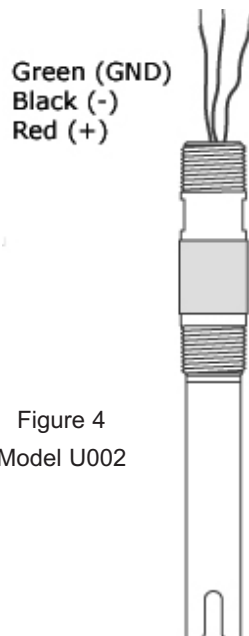

Figure 4
Model U002

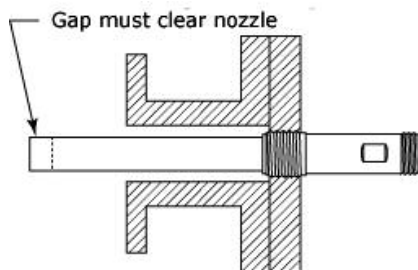

Figure 5
Nozzle Mounting

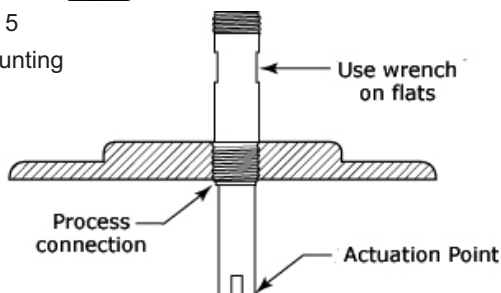

Figure 6
Vertical Mounting

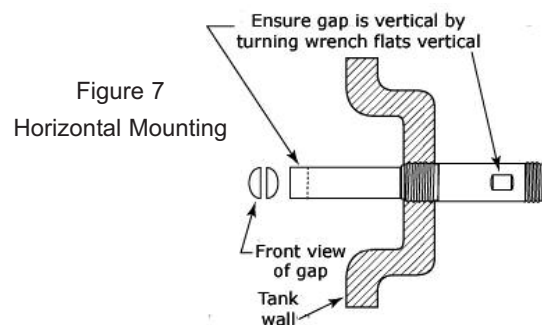

Figure 7
Horizontal Mounting

3.0 Reference Information

3.1 Specifications

3.1.1 Physical

Inches (mm)

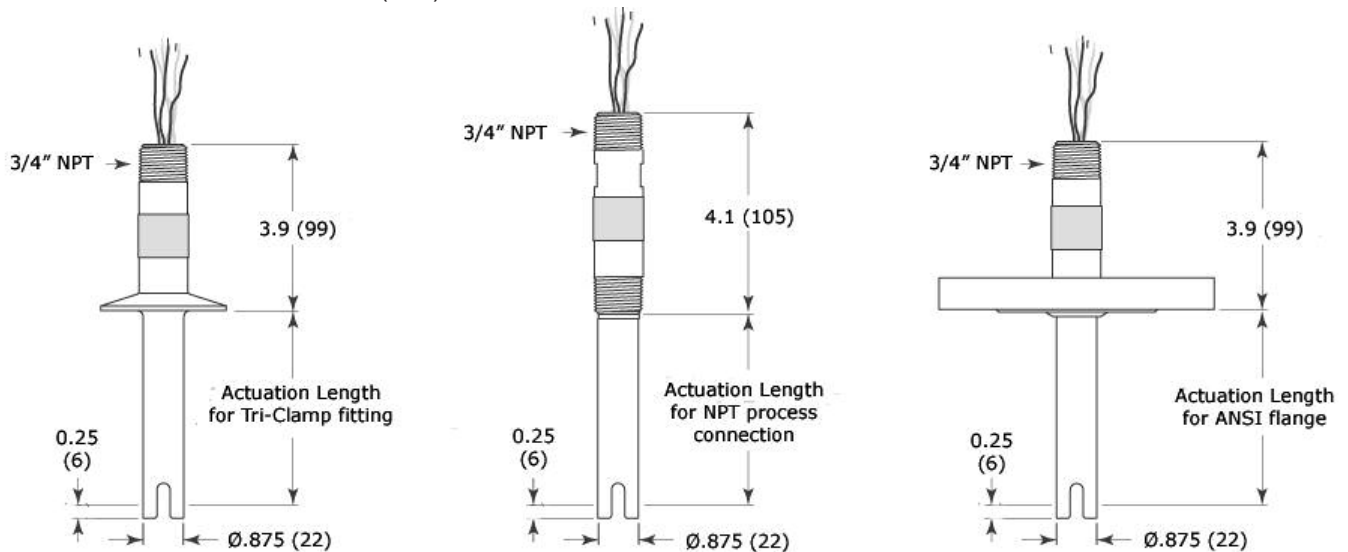

Model U002/3 with Sanitary flange

Model U002/3 with 3/4" NPT

Model U002/3 with ANSI Flange

3.1.2 Electrical

Power Supply:	12–35 VDC
Power Consumption:	Less than 1 Watt
Signal Output:	U003 Relay Model: SPDT relay, 1 amp @ 30 VDC, 0.5 amp @ 125 VDC, 0.5 amp @ 150 VAC
	U002 Current Shift Model: Dry Gap: 8 mA (±1 mA)
	Wet Gap: 16 mA (±1 mA)
Cabling:	12" (305 mm) flying leads of 18 AWG wires
Repeatability:	0.078" (2 millimeters)
Response Time:	½ second typical

3.1.3 Environmental

Ambient Temperature:	-40° to +185° F (-40° to +85° C)
Process Temperature:	-40° to +185° F (-40° to +85° C)
Maximum Pressure:	2000 psig (138 bar) for 1" (3 cm) and 2" (5 cm) transducers 1500 psig (103 bar) for transducers longer than 2" (5 cm)
Ingress Protection:	NEMA 4X (IP66)
Shock	ANSI/ISA-S71.03 Class SA1
Vibration	ANSI/ISA-S71.03 Class VC2

3.2 Replacement Parts

Model U002 & U003 units have no replacement parts. A new unit must be ordered. Consult factory.

3.3 Troubleshooting

PROBLEM	ACTION
No signal with level change	Check wiring to make sure proper input voltage is supplied.
	Make sure liquid is filling the transducer gap.
	Check for dense foam on surface or dried product in the gap. Unit may not function properly if either condition exists.
No change in output between wet gap or dry gap	Check to see if transducer gap is plugged with solids.
	Check for dense foam in gap.
The switch is chattering	Check for proper input voltage supply.
	Check for turbulence. Relocate switch or isolate from turbulence.
	Check for excessive aeration.

3.4 Model Numbers

BASIC MODEL NUMBER

U00W	Ultrasonic Level Switch
------	-------------------------

OUTPUT TYPE

2	Current Shift Output
3	Relay Output

TYPE

E	Hazardous Locations
---	---------------------

PROCESS CONNECTIONS

08	3/4" NPT
71	1" 150# ANSI flange
72	1.5" 150# ANSI flange
73	2" 150# ANSI flange
62	1"/1.5" Tri-Clamp fitting
63	2" Tri-Clamp fitting

UNIT MATERIAL

08	316 Stainless Steel
----	---------------------

CUSTOM CONFIGURATION

C	Custom Design
---	---------------

CUSTOM IDENTIFICATION

ZZZZ	Custom Design Number
------	----------------------

U	0	0	W	E	X	X	0	8	C	Z	Z	Z	Z
---	---	---	---	---	---	---	---	---	---	---	---	---	---

Contact Factory for Actuation Length
 * Minimum actuation length of 2 inches

Notes

Service Policy

Owners of Innovative Solutions controls may request the return of a control or any part of a control for complete rebuilding or replacement. They will be rebuilt or replaced promptly. Controls returned under our service policy must be returned by Prepaid transportation. Innovative Solutions will repair or replace the control at no cost to the purchaser (or owner) other than transportation if:

1. Returned within the warranty period; and
2. The factory inspection finds the cause of the claim to be covered under the warranty.

If the trouble is the result of conditions beyond our control; or, is NOT covered by the warranty, there will be charges for labor and the parts required to rebuild or replace the equipment.

In some cases it may be expedient to ship replacement parts; or, in extreme cases a complete new control, to replace the original equipment before it is returned. If this is desired, notify the factory of both the model and serial numbers of the control to be replaced. In such cases, credit for the materials returned will be determined on the basis of the applicability of our warranty.

No claims for misapplication, labor, direct or consequential damage will be allowed.

Return Material Procedure

So that we may efficiently process any materials that are returned, it is essential that a "Return Material Authorization" (RMA) number be obtained from the factory, prior to the material's return. This is available through Innovative Solutions local representative or by contacting the factory. Please supply the following information:

1. Company Name
2. Description of Material
3. Serial Number
4. Reason for Return
5. Application

Any unit that was used in a process must be properly cleaned in accordance with OSHA standards, before it is returned to the factory.

A Material Safety Data Sheet (MSDS) must accompany material that was used in any media.

All shipments returned to the factory must be by prepaid transportation.

All replacements will be shipped F.O.B. factory.

NOTE: See Electrostatic Discharge Handling Procedure on page 2.



60 Great Hill Road Naugatuck, CT 06770
ph: 203-729-6434 fax: 203-729-6696

www.innovativesensing.com

BULLETIN: IS-9410.2
EFFECTIVE: June 2010